



--SAFETY REQUIREMENTS FOR OPERATING A LASER AT FABTECH MEXICO --

An ENCLOSURE for any laser machine that will be operated during show hours, in any mode, is **mandatory**.

- Your equipment must be in fully enclosed to avoid any possible “leaking” of the laser beam.
- Be aware that the laser beam, able to cut metal, will cause damage to any other material in its trajectory, so safety precautions to protect both equipment and people must be observed.
- The integrated dust collector must work properly to avoid the expulsion of fumes.
- The glass must be “specially coded glass for laser use”, compliant with industry standards.
- Prior to running or testing your laser, show management must be notified and the laser enclosure will be checked for compliance with all safety requirements.
- The person responsible for the safety, operation, and demonstration of the equipment must sign and return this letter to the show management, acknowledging receipt and compliance with these requirements.
- Please submit specifications of the gas connections needed (plugs, diagrams, pictures, etc.) to show management prior to arrival at the hall.

SAFETY FIRST!

Signed By: _____

Company: _____ Booth: _____

Please return this document to the *Laser Safety Officer (LSO)* Steven Glover lasersafety@fabtechexpo.com and Show Management to Celina García celina.garcia@fabtechmexico.com



Laser Safety Information Booklet for
Exhibitors with Active Laser Systems



Exhibitor Laser Safety Policy

The purpose of this booklet is to provide guidance in laser safety for our exhibitors with active laser systems, registration and compliance with all United States regulations, and laser safety requirements from the *Laser Institute of America (LIA)*. The safety of all attendees, employees, and exhibitors is our primary goal.

FABTECH has adopted these laser safety rules to ensure a safe and professional conference for exhibitors and visitors. All exhibitors using lasers must understand and follow these rules. FABTECH will stop any laser activity that it deems to be unsafe.

FABTECH Show Management and its appointed officers are available for pre-show and on-site questions.

FABTECH México Laser Safety Officer (LSO):

Steven Glover

+1.407.334.7332

lasersafety@fabtechexpo.com

FABTECH México Show Management:

Celina García

+52.81.8800.4166

celina.garcia@fabtechmexico.com

Wednesday, April 12th, 2024

Laser Safety Rules

1. All laser systems no matter what class **must be registered before Wednesday, April 12th, 2024**. See the laser system registration form in this booklet.
2. If you will be operating a laser, no matter how low-powered, you are **REQUIRED** to register for an onsite safety check prior to opening. All equipment operation is subject to inspection and approval by the **Laser Safety Officer (LSO)**.
3. FABTECH requires that all lasers be operated in accordance with the laser safety guidelines specified in *ANSI Z136.1 American National Standard for Safe Use of Lasers*.
4. All lasers and laser systems must comply with the Center for Devices and Radiological Health (CDRH) CFR Title 21 part 1040. These standards can be found on the CDRH website. <https://www.accessdata.fda.gov/scripts/cdrh/cfdocs/cfcfr/CFRSearch.cfm?FR=1040.10>
5. Exhibitors shall use appropriate safety measures to prevent any unwanted or unintentional laser radiation exposure to any convention center staff or workers during the pre-show set-up.
6. Exhibitors are responsible for the safe management of their booth space during set-up, exhibit hours, breakdown, and during any laser operation. Exhibitors assume all risk and liability for any hazards and/or injury that may result from failure to comply with laser safety standards. Exhibitors or device providers are required to correct any hazardous conditions prior to operation.
7. All displays containing an operating laser(s) and open laser beam (class 3B and 4) **must be contained in a Class 1 type enclosure**. Additionally, all laser equipment, associated optics or equipment, and beam stops are required to be secured from any movement (accidental or otherwise).
8. Any windows on the class 1 enclosure must be of an optical density (OD) rating appropriate for the wavelength of the laser being used in the demonstration.
9. All laser systems that are in class 1 enclosures that produce plasma emissions must have windows or provide eye protection of an appropriate optical density to protect against the plasma emission.
10. All laser system interlocks must be functioning.
11. Use of high-volume smoke evacuation during laser operation is required.
12. No laser equipment may be left unattended in operable condition. If the booth or exhibit is left unattended, the laser must be deactivated and the key must be removed from the laser.
13. No aerial display of any laser beam within the convention center property, including assigned booth, is allowed without FABTECH exhibition management's written permission.
14. Compressed gas or compressed liquid cylinders used in the booth must be securely anchored to prevent toppling. Only a one-day, secured supply will be allowed in the display area. It is the exhibitors' responsibility to ensure that all compressed gas cylinders are properly secured at all times.

These rules ensure a safe environment for everyone. If the laser does not meet the minimum safety requirements, its use will not be allowed during the exhibition until the necessary measures are taken.



Wednesday, April 12th, 2024

Laser System Registration Form

All laser systems no matter what class must be registered with FABTECH before **Wednesday, April 12th, 2024**. All displays containing an operating laser(s) and open laser beam (class 3B and 4) **must be contained in a Class 1 type enclosure**. Please fill out the information below and submit it to the FABTECH Show Management.

Company name: _____ Booth: _____

Address: _____

_____ City: _____

State: _____ Country: _____ ZIP Code: _____

Contact name from the Company: _____

Email: _____ Mobile: _____

FABTECH México Laser Safety Officer (LSO):

Steven Glover

+1.407.334.7332

lasersafety@fabtechexpo.com

FABTECH México Show Management:

Celina García

+52.81.8800.4166

celina.garcia@fabtechmexico.com



LASER SAFETY INSPECTION REGISTRATION

Deadline: Wednesday, April 12th, 2024

Exhibition Dates: May 7-9, 2024

Companies displaying an active laser are REQUIRED to register for an onsite safety check prior to the exhibit opening. Final safety inspection will take place during the following times:

Monday, May 6th, from 8:00 AM to 4:00 PM

Please return this form before the deadline to the **Laser Safety Officer (LSO) Steven Glover** lasersafety@fabtechexpo.com and celina.garcia@fabtechmexico.com

REQUIREMENTS: All displays containing an operating laser and open laser beam must be contained in a Class 1 type enclosure. Additionally, all laser equipment, associated optics or equipment, and beam stops are required to be secured from any movement (accidental or otherwise).

Exhibiting Company: _____ Booth Number: _____

Pre-show Contact: _____

Phone: _____ Email: _____

Onsite Contact: _____ On site Cell Number: _____

Please indicate (X) your requested inspection date and time range:

Monday, May 6th: 8:00am – 12:00pm or 12:00pm – 4:00pm

Laser Equipment must be set up prior to Safety Check.

Please provide an overview of the equipment to be inspected:

Deadline: Wednesday, April 12th, 2024

Questions? Contact the **Laser Safety Officer (LSO) Steven Glover** at +1.407.334.7332 or lasersafety@fabtechexpo.com



Exhibitor Laser Safety Checklist

- Did you fill out the laser system registration form?
- Did you fill out your laser safety inspection form?
- Did you read the exhibitor laser safety policy?
- Are all the interlocks on your laser working?
- Does your laser system have a smoke evacuation system?
- **Does your laser system and enclosure comply with the CDRH 21 CFR 1040?**
 - **To view the standard go to:**
<https://www.accessdata.fda.gov/scripts/cdrh/cfdocs/cfcfr/CFRSearch.cfm?FR=1040.10>
- **Do all the windows on your class 1 enclosure meet the required optical density for both the laser wavelength and plasma emissions?**
- Are all compressed gas cylinders fastened down properly?



GUIDELINES FOR SAFE LASER EXHIBITS

An effective exhibit requires careful advanced planning and preparation. As part of that process, it is imperative that consideration be given to the safety of everyone in the exhibition area. Ensuring that an exhibit is a safe one is both a personal and a corporate responsibility.

This information is not intended to be all-encompassing, and it does not spell out laser safety standards. It is your responsibility to be aware of and to conform to all applicable safety regulations and standards.

The guidelines given are intended to set the tone for the planning and conduct of your exhibit. Should you have any specific questions related to laser safety, please direct them to the **Laser Safety Officer (LSO) Steven Glover** lasersafety@fabtechexpo.com or with the Show Management of FABTECH México Celina García at celina.garcia@fabtechmexico.com

The following guidelines illustrate methods for addressing several specific safety problems.

Information obtained from a printing by the Optical Society of America.

All laser beams must terminate in a beam block that is firmly secured in place. A power meter that can be moved out of the way of the beam is not a beam block; a beam block should be provided beyond the power meter.

The beam block must be substantial and suitable for the energy and wavelength involved. It must not produce specular reflections or excessively bright, diffusely scattered light.

All fiber lasers MUST have an enclosure.

Exhibitors must be cognizant of the eye hazards that may occur during the often- hectic setup phase of an exhibit. Precautions must be taken to protect other workers in the exhibit area as well as personnel in the booth itself. The use of temporary polycarbonate shields or laser curtains around the area is an effective way to prevent beams from wandering during the exhibit setup.

Exhibitors are encouraged to bring extra material for shielding laser beams, fastening components to benches, etc. so that unforeseen problems which inevitably crop up can easily be dealt with.

The eye hazards of some non-laser light sources, such as intense UV arc lamps, flash lamps, and plasma, should be recognized, and appropriate safety precautions should be employed.

THE NEXT PAGE SHOWS ADDITIONAL SAFETY PRECAUTIONS THAT MAY BE USED.

Beam Enclosure

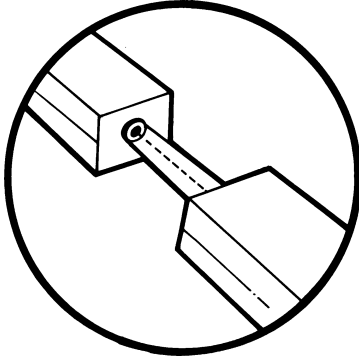

Any potentially dangerous laser beams must be enclosed or otherwise made inaccessible to visitors. The enclosures or guards must be sturdy enough and well enough secured to resist normal bumps and jostling and even casual, curious removal. An example, using simple materials, is shown here. A clear plastic tube encloses a laser beam as it passes from one device to another; the tube is firmly attached to each device.

Demonstrating Internal Laser Elements

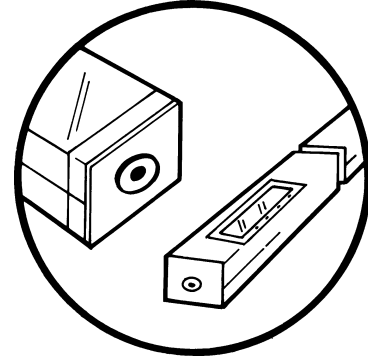

Visitors often want to view the interior of working lasers or similar devices. Removing the cover of a working laser should not be done since this can expose persons in the exhibit to thermal, electrical, and optical hazards. One effective solution that has been widely employed is the use of clear or smoked plastic covers in place of the usual opaque laser covers. Another approach uses similar plastic to cover openings cut in the standard laser cover. Remember that reflections from internal optical surfaces and radiation from bright sources that are usually blocked by the cover may emerge through the semitransparent plastic. Check for them carefully and provide internal beam blocks where required.

Demonstrating Laser Interaction Phenomena

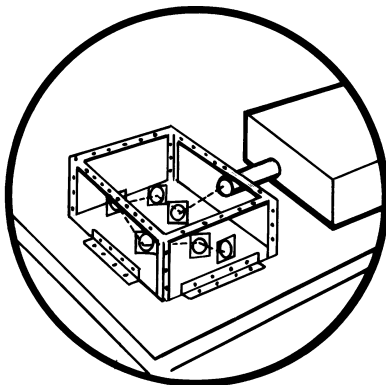

A simple, but sturdy, plastic box can be used to enclose tabletop space in which multiple beams are involved in various interactions. Once again, carefully check to see that no stray beams leave the box; block them internally. This technique has the additional advantage of preventing curious visitors from readjusting the alignment.

Video Demonstration

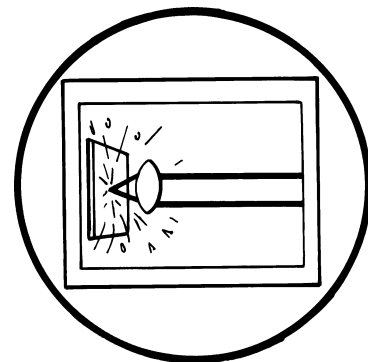

Dramatic demonstrations for which adequate safety precautions would be difficult might effectively be demonstrated by using videotape. An example for which this approach seems particularly appropriate would be the demonstration of laser welding and cutting.